

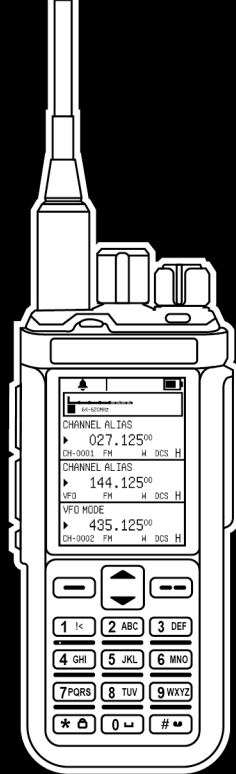

radtel RT-880G USER MANUAL



XIAMEN RADTEL ELECTRONICS CO.,LTD
502, No.1, Jinyi Wuli, Huli, Xiamen, Fujian,China 361004
Email: support@radtel.com
Website:www.radtel.com



Table of Contents

Familiar with Radio		FM Radio & Shortwave Receiver	09
Overview of Components	01	One-Key Frequency Measurement & Remote	
Keypad and keys Function	03	Sub-Audio CTCSS/DCS Decoding	10
		Spectrum	10
LCD Display		List of all menus	
Symbols & Indicators	06	1.1 Basic Setting	11
		1.2 Key Define	15
Two-Way Radio Charging Guide		1.3 Analog Setting	16
Charging Methods	07	1.4 CH Settings	19
LED Indicator Status	07	1.5 Zone Settings	20
		1.6 FM RADIO	20
Basic Operation		1.7 Time Management	21
1.1 Setting Working Frequency	07	1.8 GPS	22
1.2 Frequency Input	07	1.9 APRS	24
1.3 Repeater Frequency Input	07	Advanced Operation	28
1.4 Transmitting Signals	08	Key Define	29
1.5 Receiving Signals	08	Analog Settings	30
1.6 CTC/DCS Settings	08	CH Settings	31
1.7 U/V Cross-Band Repeater	08	Zone Settings	32
1.8 DTMF Function	08	Trouble Shooting Guide	33
1.9 Text Input Function	09	Technical Specification	34
		SAFETY & GENERAL INFORMATION	35

Familiar with Radio

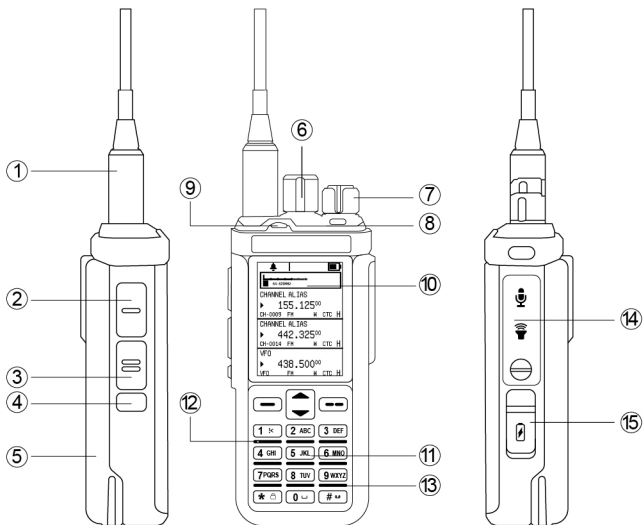



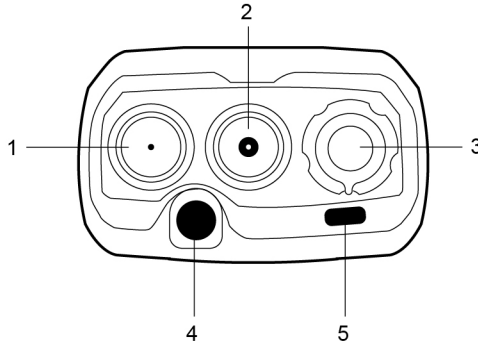

- ①Antenna ②PTT ③Side-key 1 ④Side-key 2 ⑤Battery ⑥SW/MW/LW FM antenna(Channel knob)
⑦ON/OFF volume ⑧ Indicator Light ⑨Alarm Button ⑩Display screen ⑪ Keypad ⑫ MIC
⑬ Speaker ⑭ Ear/Mic jack ⑮ Type C charging port/programmable jack

Familiar with Radio



1. **Antenna Port 1:** Used for all frequency transmission and reception except short wave/middle wave/long wave/FM radio frequencies.
2. **Antenna Port 2:** Used for short wave/middle wave/long wave/FM radio frequencies.
3. **Power Button/Volume Adjustment:** Used to turn the device on/off and adjust the volume.
4. **Emergency Alarm Button/Customizable Button:** Can be used for emergency alarms or customized functions.
5. **LED Light:**
Green Light: Indicates the device is receiving a signal.
Red Light: Indicates the device is transmitting a signal.

Keypad Function

Keys	FUNCTION
PTT	Transmit or Exit
Alert Key	Definable long press (L) and short press (S) functions
Side Key1	You can select the [Multi-PTT Switch] option in the menu to use it as PTT-2 for transmission, which will disable the custom function.
	Definable long press and short press functions
Side Key2	Definable long press and short press functions
	You can select the [Multi-PTT Switch] option in the menu to use it as PTT-3 for transmission, which will disable the custom function.
	Short press to confirm or enter into menu
	Long press to enter DTMF inputting while under standby status, or to exit while under menu interface
	DTMF :A
	Move up; long press to quickly scroll up.
	DTMF :B
	Move down; long press to quickly scroll down.
	DTMF :C
	Short press: Switch ABC channels, exit the menu, and cancel the operation.
	DTMF :C
0	Short press: Enter the number 0.

Keypad Function

Keys	FUNCTION
0	Long press to definable functions, or switch scanning direction in FM RADIO mode
	DTMF :0
	To input Number 0 or Space Bar
1	Short press: Enter the number 1
	Long press to definable functions
	DTMF :1
	to input Number 1/English Letters/Chinese Characters
2-9	short press to input Number 2-9
	Long press to definable functions
	DTMF :2-9
	to input Number2-9/English Letters/Chinese Pinyin Codes
*	short press to switch from channel frequency /channel number/channel Alias, Move the cursor in FM RADIO mode
	long press to lock the keypad
	DTMF :*
	Text input: Delete text.
#	Short press: Switch the working mode to VFO frequency mode/channel mode/zone mode.
	Or switch short wave modulation in FM RADIO
	Long press: Jump to the transmit frequency input menu. Or switch short wave mode in FM

Keypad Function

Keys	FUNCTION
#	RADIO
	DTMF :#
	Text input: Enable or disable text input, switch text input method.

LCD Display

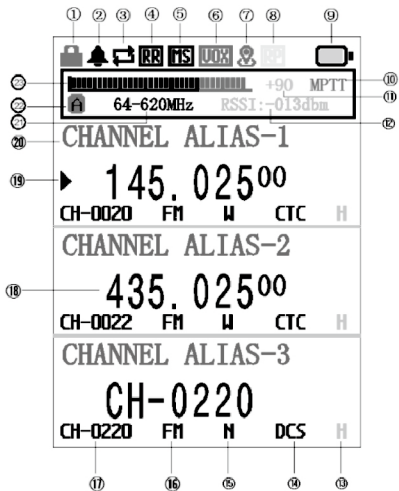

- 1.Keyboard Lock
- 2.Prompt Tone
- 3.Scan
- 4.RR: Talk around/TR: Reverse Frequency
- 5.Multi-Frequency Standby
- 6.VOX
- 7.GPS (option function)
- 8.Cross-Band Repeater
- 9.Battery Icon
- 10.Multi-PTT Enable
- 11.Received Signal Strength
- 12.Received Signal Field Strength Value
- 13.High Power / Low Power switchable
- 14.CTCS / DCS / MUT Non-standard DCS / ENC Encrypted DCS
- 15.Wide or Narrow Bandwidth
- 16.FM /AM RX
- 17.CH-XXXX: channel number in channel mode / ZONE-XXX: zone number in zone mode
- 18.Working Frequency / Working Channel
- 19.Main Frequency Area Indicator Icon
- 20.Channel Name
- 21.Working Frequency Range
- 22.A/B/C Main Frequency Area
23. Received Signal Meter

Charging Radio

Your two-way radio supports three charging methods:

1. Charging with the Radio in the Charging Dock

Insert the battery into the radio.

Place the radio into the charging dock.

Ensure the radio is properly seated in the charger.

2. Charging the Battery Alone in the Charging Dock

Remove the battery from the radio.

Insert the battery into the charging dock.

Make sure the battery is aligned correctly.

3. Charging via USB-C Cable

Plug a USB-C cable into the charging port on the side of the radio.

Connect the other end of the cable to a power adapter, computer, or power bank.

LED Indicator Status

Red Light: Charging in progress.

Green Light: Charging complete.

Note:

Use only the recommended charger and cables.

Do not charge in extreme temperatures.

Fully charge the battery before first use for optimal performance.

Not to use cell phone fast charger to charge this radio.

Basic Operation

1.1 Set Working frequency

1.11 The device operates in three frequency ranges: 64-620 MHz, 18-64 MHz, and 840-1000 MHz. Transmission and reception for all three bands are handled via the left main antenna port.

1.12. To change the frequency band, navigate to [Basic Settings] → [17 Work Range] in the menu. After selecting the desired frequency band and confirming, the device will restart.

1.13. Important: Ensure that you replace the antenna with one that matches the selected frequency band. Using an incorrect antenna may result in damage due to frequency mismatch.

1.2. Frequency Input

1.21 Switch to VFO Frequency Mode: Press the # key to enter VFO Frequency Mode.

1.22 Enter the Frequency:

Use the numeric keypad to input the desired frequency. The input must be either 6 digits or 8 digits, depending on the selected setting.

1.23 Frequency Input Settings:

Navigate to [Basic Settings] → [Frequency Input 30].

Select [6 Bits] to allow 6-digit frequency input.

Select [8 Bits] to require 8-digit frequency input.

1.3 Repeater Frequency Input

Method 1: Using Offset Frequency Settings

1. Navigate to [CH Settings] → [16 Offset Freq] and use the numeric keypad to input the offset frequency.

2. Go to [CH Settings] → [15 Offset Direction] and select either positive or negative offset.

Method 2: Direct Transmit Frequency Input

1. In standby mode, long press the [#V/M] key to enter the [Transmit Frequency] menu.
2. Use the numeric keypad to enter the desired transmit frequency, then press OK to confirm. The device will return to the previous menu.
3. Go to [CH Settings] to access the sub-audio settings menu and configure the sub-audio frequency as needed.

1.4. Transmitting Signals

1.41 Standard Transmission

Press the PTT key to initiate a call on the current frequency.

The LED indicator will turn red during transmission.

1.42 Multi-PTT Mode (If enabled in [Key Definition] → [1 Multi-PTT])

1.43 When Multi-PTT Mode is active, the shortcut functions of Side Key 1 and Side Key 2 are disabled.

1.44 Side Key 1: Transmits on Band B.

1.45 Side Key 2: Transmits on Band C.

1.5 Receiving Signals

When the device receives a signal on the same frequency, the LED indicator will turn green.

Audio output will be enabled if:

1. No sub-audio (CTC/DCS) is set, or
2. The received sub-audio matches the configured sub-audio on the device.

1.6 CTC/DCS Settings

Navigate to [CH Settings] to set the sub tone CTCSS or DCS.

1.61 CTC/DCS (Transmit & Receive) – Enables both transmit and receive CTC/DCS. The device will only communicate with signals that match the set code.

1.62 RX CTC/DCS (Receive Only) – The device will only accept signals that match the set CTC/DCS code, but transmission remains unrestricted.

1.63 TX CTC/DCS (Transmit Only) – The device will transmit using the set CTC/DCS code, but it will receive all incoming signals without restriction.

1.7 U/V Cross-Band Repeater

1.71 Activating Cross-Band Repeater Mode

Assign a button to [26 UV Repeater] for quick activation. Alternatively, enable it via [Basic Settings] → [28 UV Repeater].

Once activated:

Channel C is disabled.

Only Channels A and B are used for cross-band repeating.

Signals received on Channel A are retransmitted on Channel B.

Signals received on Channel B are retransmitted on Channel A.

1.72 Monitoring Repeater Audio

Enable [29 Repeater Monitor] in [Basic Settings] to listen to repeater voice communications.

1.8 DTMF Function

DTMF Encoding Input & Transmission

1.81 Accessing DTMF Input Mode

In standby mode, long press the — key to enter the DTMF input interface.

1.82 Entering DTMF Codes

Use the numeric keypad to input the DTMF codes. Short press Side Key 2 to delete the last entered digit.

1.83 Transmitting DTMF Codes

Press the PTT key to initiate a call. The device will send the DTMF code after a preset delay.

DTMF Decoding

When the device receives a signal and DTMF decoding is enabled, the received DTMF code will be displayed on the screen.

DTMF Transmission in Analog Mode

During analog transmission, pressing a key on the keypad will send the corresponding DTMF code.

DTMF Remote Monitoring

- ① Set a DTMF monitoring code for the device and enable [Accept Remote Control].
- ② Another radio can send the same DTMF code to this device.
- ③ Upon receiving and successfully decoding the DTMF code, the device will automatically transmit for 60 seconds, enabling remote monitoring.

DTMF Remote Stun/Kill/Wake

1. Setting Remote Control Codes

Set the DTMF remote stun/kill/wake code for the device and enable [Accept Remote Control].

2. Sending Remote Commands

Another radio can send the corresponding DTMF code to remotely stun, kill, or wake the device.

3. Device Behavior

Stunned: The device cannot transmit or operate the keypad but can still receive signals.

Killed: The device becomes inoperable until it receives a wake code.

4. Important Warning:

Ensure a wake code is set before enabling stun/kill functionality, as the device cannot be restored once stunned or killed without a wake code.

1.9 Text Input Function

1. In the Text Input Menu:

- # key: Switch between different input methods.
- * key: Delete text or pinyin.

2. Number Input [123]:

Use the numeric keypad to enter numbers.

3. English Input [AB] / [abc]:

Keys 2-9: Input corresponding letters.

0 key: Inputs a space.

1 key: Inputs symbols.

Press a key multiple times to cycle through the letters (e.g., pressing 2 will display A, B, C sequentially).

4. Chinese Pinyin Input [PY1] / [PY2]:

PY1: Common Chinese characters.

PY2: A more extensive character set, including rare and traditional characters.

Enter pinyin using the numeric keypad, use ▲ ▼ keys to select characters, and press the — key to confirm.

2.0 FM Radio(activate MW/SW/LW Short wave radio receiver)

1. Defining the FM Radio Trigger

Go to the menu, then Key Define to assign a button for the FM Radio function.

Pressing the defined button will enter radio mode.

Pressing the PTT key will exit radio mode.

2. Switching Between Radio Bands

Long press the # key to switch between radio bands:

USW (Ultra Short Wave: 64-108 MHz)

SW (Short Wave: 2.0-30.0 MHz)

MW (Medium Wave: 520-1710 KHz)

LW (Long Wave: 153-279 KHz)

3. Switching Demodulation Modes

Short press the # key to switch the radio's demodulation mode.

The USW band is fixed to FM (Frequency Modulation), which cannot be changed.

Other bands can switch between:

AM (Amplitude Modulation)

USB (Upper Sideband)

LSB (Lower Sideband)

CW (Continuous Wave, Morse Code)

4.* Key Short Press: Switches the Input Type

When the ◀ symbol is pointing to the radio frequency, you can manually enter a frequency value to change the frequency.

When entering other types of data, press the ▲ ▼ keys to switch the data content.

For example, channel numbers can be directly input to switch to the corresponding channel.

5.* Key Long Press: Enter Scan Mode

Press any key to exit scan mode.

When the radio is not in scan mode, long press the 0 key to switch the scan direction.

6.Single Sideband (USB/LSB) Demodulation:

If you encounter sharp sound, lower the BFO (Beat Frequency Oscillator) frequency.

If the sound is too deep, increase the BFO frequency.

2.1 One-Key Frequency Measurement & Remote Sub-Audio CTCSS/DCS Decoding

1.After pressing the trigger button, the device enters Frequency Measurement or Remote Sub-Audio Decoding Mode and starts scanning surrounding RF signals.

2.Press the * key to switch between Frequency Measurement Mode and Remote Sub-Audio Decoding Mode.

3.During frequency measurement:

Press the PTT key or exit key to exit.

Press the # key to switch the frequency band.

4.After completing frequency measurement:

Press the exit key to re-measure.

Press the menu key to save the measurement result to the VFO channel and return to VFO standby mode.

Press the PTT key to transmit.

2.2 Spectrum

Spectrum Scanning Mode

1.Press the trigger button to enter Spectrum Scanning Mode. Press the * key to exit.

2.Short press the * key to switch input fields. The spectrum display interface includes three input items:

Scan Center Frequency (top-left): Adjusting this moves the scan center point.

SPACE: Scan step size (frequency interval between adjacent waveforms), unit: kHz.

DECAY: Signal amplitude attenuation, lowering the overall spectrum height for clearer observation of the main signal and adjacent channels.

3.Press ▲ ▼ to move the indicator cursor. The bottom display will update to show:

Frequency at the cursor position.

RSSI (Received Signal Strength Indicator).

NOISE (Signal noise intensity).

GLITCH (Spurious signal strength).

2.3 List of all menus

Basic Settings			
NO	Menu	Second Menu	
1	Name/Callsign	customize	Set the name or callsign of the walkie-talkie.
2	Voice Prompt	Off/On	Turn on/off the voice prompt.
3	Key Beep	Off/On	Turn on/off the key beep
4	Lock Timer	Off/5s~600s	Set the lock time (5 seconds to 600 seconds).
5	Key LED Timer	Off/On	Turn on/off the key LED indicator
6	LCD Timer	Off/5s~600s	Set the timed-off time for the LCD display(5 to 600 seconds)
7	Brightness	0~4	Adjust the brightness of the LCD display (0 to 4)
8	Menu Exit	Off/5s~600s	Set the timed-off time for menu exit(5 to 600 seconds).
9	TX Priority	Edit	You can edit the transmit priority.
		Busy	Indicates that the current transmitter is busy.
10	Freq Step	0.25K/1.25K~5M	Set the size of the frequency step. You can choose from 0.25K, 1.25K to 5M.
11	Talkaround	Off/Talk around/ Invert Freq	Talkaround mode allows direct communication on the same frequency without using a repeater, enhancing simplicity and reducing reliance on infrastructure for communication.
12	Save Mode	Off/1:1/1:2/1:3	Turn off the save mode.Save the one-to-one/Two /Three mode
13	Scan Mode	CO/TO/SE	Channel/Time/Search scan
14	Scan Direction	Up/Down	Scan upwards/Scan downwards.

Basic Settings

NO	Menu	Second Menu	
15	Scan Return	Original CH	Return to the original channel.
		Current CH	Return to the current channel.
16	Alarm Type	Local Alarm	Local alarm
		Remote Alarm	Remote alarm
		Local+Remote	Local and remote alarms
17	Work Range	64-620MHz	
		18-64MHz	Set the frequency range.
		840-1000MHz	
18	Area A Mode	Freq Mode	
		CH Mode	Set the Channel mode, Frequency model or zone mode.
		Zone Mode	
19	Area A Show	Show CH No	Set the display way in the selected mode
		Show Freq	
20	Area A Zone	Zone-001~256	Set the zone numbers
21	Area B Mode	Freq Mode	Set the Channel mode, Frequency model or zone mode
		CH Mode	
		Zone Mode	
22	Area B Show	Show CH No	Set the display way in the selected mode
		Show Freq	

Basic Settings

NO	Menu	Second Menu	
23	Area B Zone	Zone-001~256	Set the zone numbers
24	Area C Mode	Freq Mode	Set the Channel mode, Frequency model or zone mode
		CH Mode	
		Zone Mode	
25	Area C Show	Show CH No	Set the display way in the selected mode
		Show Freq	
26	Area C Zone	Zone-001~256	Set the zone numbers
27	Multi Standby	Off/On	The multi-standby mode allows the device to switch between multiple frequencies or signals while remaining in standby status.
28	UV Repeater	Off/On	Cross band repeater function.
29	Repeater Monitor	Off/On	Monitor the working status of the repeater in real time including signal strength, connection status, etc.
30	Freq Input	6 bits	The device can receive and process signals of different frequencies, with the supported frequency input range being 6 or 8 digits.
		8 bits	
32	Save CH	CH-0001 Y~	Save frequently used channels in the device for quick access.
		CH-0008 Y~	
		CH-1024 N	

Basic Settings

NO	Menu	Second Menu	
32	Delete CH	CH-0001 Y~	Delete channels that are no longer needed from the device to keep the channel list tidy and orderly.
		CH-0008 Y~	
33	Version	CH-1024 N	
		UV Radio	Show the version information
		V1.05 2025	
34	Initialization	Cancel	Confirm or cancel the Initialization
		Ensure	

Key Define

Key Define			
NO	Menu	Second Menu	
1	Multi PTT	Off/On	Set the side key 1 and side key 2 as the PTT button, if enable, it will disable the defined button
2	Side Key 1S	None	Set the side key 1, side key 2, Alarm key, Num0-9 short press or long press
3	Side Key 1L	Monit	
4	Side Key 2S	Power Switch	
5	Side Key 2L	Scanning	
6	Alarm Key 2S	VOX	
7	Alarm Key 2L	SQ	
8	0 Press Long	Freq Step	
9	1 Press Long	Multi Standby	
10	2 Press Long	TX Priority	
11	3 Press Long	Roger Beep	
12	4 Press Long	FM Radio	
13	5 Press Long	Talkaround	
14	6 Press Long	Alarm	
15	7 Press Long	Send Single Tone	
16	8 Press Long	Freq Detect	
17	9 Press Long	CTC/DCS Scan	

Analog Settings

Analog Settings			
NO	Menu	Second Menu	
1	SQ Level	0~10	0-10 adjustable sensitivity for optimizing reception in varying signal conditions.
2	TX Start Tone	Off/On	Customizable audio tone when power On.
3	TX End Tone	Off	Customizable audio tone at end of transmitting
		Roger Beep 1	
		Roger Beep 2	
		Send Radio Name	
4	Single Tone	1750Hz	When the radio transmits a 1750 Hz tone, it is generally recognized by the repeater, which will activate and allow the transmission to go through. .
5	VOX On-off	Off/On	Toggleable voice-controlled transmission
6	VOX TH	0~254	Set vox level.
7	VOX Delay	0~5	Delay time after voice activation.
8	Detect Range	18-620MHz	Detects signals within the specified frequency range.
		840-1000MHz	
9	Repeater Delay	0~2000ms	Delay time for use via repeater.
10	MIC Gain	0~31	Adjusts the microphone gain.
11	FM Mode SPK Gain	0~63	Adjusts the speaker gain in FM mode.

Analog Settings

NO	Menu	Second Menu	
12	FM Mode DAC Gain	0~15	When experiencing sound distortion, lower the volume a bit.
13	AM Mode SPK Gain	0~63	Adjusts the speaker gain in AM mode
14	AM Mode DAC Gain	0~15	When experiencing sound distortion, lower the volume a bit
15	Glitch TH	0~10	Adjust the interference threshold.
16	DTMF Delay	0~2000ms	Adjusts the delay for DTMF signals
17	DTMF Interval	30~200ms	Sets the interval between DTMF signals
18	DTMF Duration	30~200ms	Sets the duration of DTMF signals
19	DTMF Mode	Off TX Start TX End	Controls the DTMF mode
20	DTMF Select	DTMF-01~16	Selects the DTMF signal to be used
21	DTMF Display	Off/On	Enables or disables the DTMF display
22	DTMF TX Gain	0~127	Adjusts the transmit gain for DTMF signals
23	DTMF RX TH	0~63	Sets the receive threshold for DTMF signals
24	DTMF Control	Off/On	Controls the DTMF functionality
25	Time Calibrate	Off/On	Enables or disables time calibration
26	TX Voice Refresh	0~2000ms	Sets the transmit voice refresh rate
27	RX RSSI Refresh	0~2000ms	Sets the receive RSSI refresh rate
28	Temporary Tuning	Off/On	Enables or disables temporary RX setup

Analog Settings

NO	Menu	Second Menu	
28	Temporary Tuning	0~127	Indicates the received signal strength indicator (RSSI)
		0~127	Indicates the level of noise in the received signal
		OFF/On	Enables or disables temporary power settings
		0~254	Set the power level of the frequency range

CH Settings

NO	Menu	Second Menu	
1	CTC/DCS	D023N D025N~D754N	Transmit & receive CTC/DCS
2	RX CTC/DCS		receive CTC/DCS signals
3	TX CTC/DCS		transmit CTC/DCS signals
4	TX Freq	144.125MHz	Set the transmission frequency
5	DCS Encrypt	Standard	Used to select different DCS encryption modes
		Encrypt 1	
		Encrypt 2	
		Encrypt 3	
		Mute Code	
6	Mute Code	00000000	Used to set the mute code
7	Band Width	Wide/Narrow	Used to select bandwidth (wide or narrow)
8	Tail Tone	Off/On	Used to turn tail tone on or off
9	Scrambler	Off/1~8	Used to select different voice scrambling modes
10	Busy Lock	OFF	Used to control the lock state, turn off carrier matching and CTC/DCS matching functions
		Carrier Match	
		CTC/DCS Match	
11	TX Power	Low/Medium/High	Set the transmission power,can choose low,medium,or high.
12	Scan Add	Add/Remove	Add or remove scan channels.

CH Settings

NO	Menu	Second Menu	
13	TOT	Off/5~600s	Set the time-out (TOT), can choose to turn off or set the time to 5 to 600 seconds
14	CH Alias	Customizes	Customize channel aliases.
15	Offset Direction		Set the repeater offset direction
16	Offset Freq	Customizes	Customize the offset frequency.
17	AM/FM RX	AM/FM	Choose to receive AM or FM Modulation signals

Zone Settings

Zone-001~256	Edit Name	Set zone name or select channels in this zone
	Select CH	

FM Radio

RX Standby	Off/On		Switch on/off RX Standby
CH List	CH001-Empty~	Edit Name	Edit Name or Set As Current
	CH128-Empty	Set As Current	

Time Management

NO	Menu	Second Menu	
1	APO	Off/On	Turns the APO (Automatic Power Off) feature on or off
2	APO Timer	Customizes	Sets the time interval for the APO feature to turn off the device
3	AWU	Off/On	Turns the Automatic Wake-Up (AWU) feature on or off
4	AWU Timer	Customizes	Sets the time interval for the AWU feature to wake up the device
5	System Time	Customizes	Sets the current time on the device

GPS

1.GPS Positioning

2.Standalone Distance Measurement: After a successful GPS lock, on the GPS interface, you can set a starting point by briefly pressing the Menu key. After walking a certain distance, briefly press the "#" key to obtain the current distance and direction relative to the starting point.

3.Two RT-880G Devices: Two RT-880G units can send their respective GPS coordinates to each other via an end-of-transmission tone. The receiving unit will display the distance and direction to the sender.

4.GPS Track Recording and Querying: Latitude and longitude can be recorded manually or at timed intervals. After entering the GPS track record list through the menu or shortcut keys, you can view the coordinates of a specific track point, as well as its distance and direction relative to your current location—useful for locating campsites when camping outdoors.

GPS			
NO	Menu	Second Menu	
	GPS	Off/On	Turn on or off GPS background reception.
		GPS Baudrate	Set the baud rate of the GPS module. The default is 9600.If the user replaces the GPS module by himself, please refer to the specification of the GPS module to set the corresponding baud rate.
		UTC Zone	Set the time zone of the user's location
		PC Monitor	Upload GPS data to the PC through the frequency writing serial port. Users can use the serial port monitoring tool to understand the data reported by GPS
		Coordinate Type	Set the longitude and latitude display format
		[Speed Unit]	Set the unit used for speed information display

GPS

NO	Menu	Second Menu	
	GPS	[Distance Unit]	Set the unit used for distance information display
		[Altitude Unit]	Set the unit used for altitude information display
		[Fixed Latitude]	Set a fixed latitude
		[Fixed Longitude]	Set a fixed longitude
		[Fixed Altitude]	Set a fixed altitude
		[Mileage]	The total mileage of the machine
		[Mileage Type]	Mileage accumulation method,select Startup Zero,the mileage count will be cleared every time the machine is turned on,and select Keep to not clear the mileage count
		[Clear Mileage]	Clear the mileage count
		[Manual Record]	Manually record the current GPS location information
		[GPS Auto Record]	Automatically record GPS location information at a scheduled time
		[GPS Record Time]	The time interval for recording GPS information at a scheduled time
		[Query Track]	Query GPS manual and automatic records, and dynamically record the position and distance relative to the user's current position,so that users can find the location of the recorded point according to the recorded track
		[Clear Track]	Clear all recorded tracks

APRS

1.APRS Hardware Encoding/Decoding: Capable of transmitting the device's APRS information to other units, and decoding incoming APRS data from other devices. If the received APRS data includes GPS coordinates, the device will also calculate the direction and distance to the other unit.

2.APRS Data Transmission to PC: APRS data can be reported to a PC via a programming cable, allowing users to forward the APRS data through a PC-connected internet network.

APRS			
NO	Menu	Second Menu	
	APRS	[APRS On-off]	Turn on or off the APRS function
		[Station Mode]	Station type, choose to use dynamic GPS coordinates as the local coordinates or use the preset fixed coordinates under the [GPS] menu as the local coordinates
		[Beacon Setup]	Beacon settings
		[Call Sign]	Local call sign
		[SSID]	SSID
		[Symbol Table]	APRS symbol set "/" or "\"
		[Symbol]	APRS symbol selection
		[Comment]	Custom message
		[MIC-E On-off]	MIC-E compressed data switch
		[MIC-E Mode]	MIC-E compressed data type
		[Path 1]	Forwarding path 1
		[Path 1 Count]	The number of times forwarding path 1 needs to be forwarded

APRS

NO	Menu	Second Menu	
	APRS	[Path 2]	Forwarding path 2
		[Path 2 Count]	The number of times forwarding path 2 needs to be forwarded
		[TX Voltage]	Add the local voltage report to the APRS data sent Add the total number of valid satellites found by GPS
		[TX Star Count]	to the APRS data sent
		[TX Mileage]	Add the local mileage information to the APRS data sent
		[Beacon Mode]	Beacon mode
		[PTT After]	APRS transmission is linked with PTT, and APRS data is sent when PTT transmission is released
		[Smart Mode]	Smart beacon Timed beacon, APRS data will be sent once at a certain time
		[Time Mode]	Timed beacon, APRS data will be sent once at a certain time
		[Timed Time(S)]	Time interval for sending timed beacons
		[Queue Mode]	Queue beacon [Queue Interval] Queue interval
		[DIGI SETUP]	Digital forwarding settings
		[DIGI REP CH]	Digital forwarding channel,after receiving APRS data, if the path matches,it will be sent through the selected channel

APRS

NO	Menu	Second Menu	
	APRS	[DIGI1 On]	Digital forwarding 1 switch. If the information in the received APRS data is consistent with the content of DIGI 1 Name,the machine will forward the received APRS data
		[DIGI1 Name]	Digital forwarding 1 name, used to match whether the received APRS data is forwarded
		[DIGI2 On]	Digital forwarding 2 switch. If the information in the received APRS data is consistent with the content of
		[DIGI2 Name]	DIGI 2 Name, the machine will forward the received APRS data Digital forwarding 2 name, used to match whether
		[Wait Before REP]	the received APRS data is forwarded The waiting time for forwarding the received APRS data, unit: seconds
		[Remote Password]	Forwarding remote password
		[APRS RX CH]	APRS only receives and decodes on the set channel
		[APRS TX CH]	Transmitting channel when triggering APRS transmission
		[TX Level]	APRS transmission gain level
		[RX Level]	APRS reception gain level
		[Demod Tone]	APRS decoding prompt tone

APRS

NO	Menu	Second Menu	
		[TX Data Upload]	The data sent by APRS is reported to the PC via the frequency writing data line
		[RX Data Upload]	The data received by APRS is reported to the PC via the frequency writing data line
		[Beacon Pop-up]	After APRS decoding is successful, the beacon data interface pops up automatically
		[PTT Priority]	PTT priority,whether to send APRS data or start a call after triggering PTT
		[PTT Delay]	The delay time for PTT to send APRS
		[Beacon List]	[Beacon Save] Whether to store the received beacon The stored beacon record list
		[Beacon List CLR]	Clear the stored beacon list
		[APRS Init]	Initialize all APRS related data

Denoise

NO	Menu	Second Menu	
	Denoise	Off/On	Turn on or off the transmission noise reduction function

Advance Operation

Basic Settings

[Lock Timer]: Set the lock time (from 5 seconds to 600 seconds). After locking, press and hold the * key to unlock.

[Key LED Timer]: Set the key backlight. After selecting "off", the light will go out. After turning it on, the light will remain lit.

[LCD Timer]: Set the timed-off time for the LCD display (5 seconds to 600 seconds). After selecting "off", the display will remain lit

[Brightness]: Set the time for the backlight to automatically turn off. Select [Off] to disable the timer, and the backlight will no longer turn off automatically.

[Talkaround]: The Talkaround function enables walkie-talkies to communicate directly with each other without relying on a repeater. The Invert Freq function is mainly used to solve the mirror frequency interference problem.

[Save Mode]: Enabling power-saving mode can conserve battery power, but in this mode, the reception may be slower, and there may be instances of missing characters at the beginning.

[Scan Mode]: Set up as [CO], the radio will resume scanning once the received signal ends. Set up as [TO], the radio will resume scanning after it receives signal and stay for a while. Set up as [SE], the radio stops scanning once it receives signals.

[Scan Direction]: This function is used to set the scanning direction of the walkie-talkie within the frequency band.

[Scan Return]: Select [Original CH] to return to the channel that was active when the scan started after the scan is

complete. Select [Current CH] to remain on the channel currently being scanned after the scan ends.

[Alarm Type]: Select [Local Alarm] to trigger an alarm sound on this device after the alarm is activated. Select

[Remote Alarm] to send an alarm signal to the remote radio without any sound on this device. Select [Local + Remote Alarm] to trigger both an alarm sound on this device and send an alarm signal to the remote radio.

[Work Range]: Switch between the 16-64MHz / 64-620MHz / 840-1000MHz working frequency bands. After switching, the radio will restart. Please replace the antenna with the corresponding frequency band antenna in time

[Multi Standby]: After enabling, the device will simultaneously monitor signals on the A, B, and C frequency bands. However, only one band can be in receiving mode at any given time.

[U/V Repeater]: Enable or disable the U/V repeater function. When enabled, Channel C will be unavailable.

[Repeater Monitor]: Monitor the working status of the repeater in real time, including signal strength, connection status, etc.

[Save CH]: Save frequently used channels in the device for quick access.

[Delete CH]: Delete channels that are no longer needed from the device to keep the channel list tidy and orderly.

[Version]: Show the version information

[Initialization]: Restore the frequency data of this device to the state of the last frequency programming.

Key Define

[Multi PTT]: When enabled, side key 1 will function as PTT-2 to transmit on frequency B. The custom function assigned to side key 1 will be disabled. Side key 2 will function as PTT-3 to transmit on frequency C, and its custom function will be disabled.

Key Define Functions & Operations

1.None: No function

2.Monitor: Opens the receiver audio.

3.Power Switch: Toggles high/low power.

4.Scanning: Initiates scanning (any key to exit).

5.VOX (Voice-Activated Transmission): Enables/disables.

6.SQ: Adjust squelch settings.

7.Freq Step: Set frequency step size.

8.Multi Standby: Enable/disable Triple frequency monitoring.

9.TX Priority: Switch the Priority Transmission Mode to either "Edit" or "Busy." When set to "Busy," the main frequency band will automatically switch to the last active call frequency after the conversation ends.

10.Roger Beep: Switching the Transmit End Tone Type for Analog Channels

11.FM radio (see description 1.9)

12.Talk around: Switching Repeater Channel Frequency to Off-Network or Reverse Mode

In Off-Network Mode, the transmit signal will be sent using the receive frequency.

In Reverse Mode, the transmit and receive frequencies are swapped.

13.Alarm: After pressing the trigger button, the device will enter Emergency Alarm Mode and emit an alert tone.

Press any key to exit.

14.Send single tone: After pressing the trigger button, the device will transmit a single-tone signal on the current frequency. Press any key to stop transmission.

15.Freq Detect: (see description 2.0)

16.CTC/DCS scan (see description 2.0)

17.Spectrum (see description 2.1)

18.Radio sleep: Low Power Sleep Mode

After pressing the trigger button, the device enters low-power sleep mode. It will wake up either when the button is pressed again or when the auto-wake timer reaches the preset duration.

Note: The system time is not retained when powered off. To maintain system time while the device is off, use Forced Sleep Mode instead of shutting down.

19.Query status: After pressing the trigger button, the device will display the current battery voltage and other status information

20.Save CH: After pressing the trigger button, the device will navigate to the "Save Channel" menu to save the channel data.

21.RX AM/FM: Switch the current channel to AM or FM reception modulation mode. The AM mode is typically used for receiving aviation band information.

22.NOAA CH: After pressing the trigger button, the device enters NOAA Weather Forecast Scanning Mode. You can switch weather forecast channels using the channel knob. If no operation is performed within 6 seconds, the device will automatically start scanning weather forecast channels.

Below are the 11 NOAA weather forecast frequencies:

(Here, you can list the specific frequencies of the NOAA weather forecast channels.)

1	162.550	7	162.5250
2	162.400	8	161.650
3	162.475	9	161.775
4	162.425	10	161.750
5	162.450	11	162.000
6	162.500		

23.LCD on-off: To turn on or off the display backlight.

24.LCD Brightness: To adjust the display backlight brightness.

25.Key LED on-off: To turn on or off the keyboard backlight

26.UV Repeater: Cross-band Repeater

The function of receiving a UHF signal on frequency A and transmitting it through frequency B on the VHF band

Analog Settings

[SQ Level]: The higher the value, the deeper the squelch, making it harder to open the reception.

[TX End Tone]:After the transmission is completed, a selected specific tone is emitted to provide feedback to the user, confirming that the communication operation is completed.

[MIC Gain]: Adjust the microphone sensitivity. The higher the value, the higher the sensitivity..

[SPK Gain]: Adjust the receiving audio volume. The higher the value, the louder the received audio. To avoid distortion in the received sound, the SPK gain should not be set too high.

[DTMF Delay]: When initiating a call, the DTMF tone will be transmitted after the set delay time.

[DTMF Interval]: Set the interval time between two DTMF tones.

[DTMF Duration]: Set the duration of a single DTMF tone.

[DTMF Mode]: Used to set the timing of DTMF transmission when initiating a call. When [Off] is selected, the transmission signal will not send a DTMF tone.

[DTMF Selection]: Select one of the 16 preset DTMF codes to be transmitted when initiating a call.

[DTMF Display]: When [On] is selected, the received DTMF code will be displayed on the screen.

[DTMF Tx Gain] and **[DTMF RX TH]:** Some different-brand radios may experience difficulties decoding DTMF codes. By adjusting these two options, you can maximize compatibility with DTMF codes from different radio brands. It is recommended to set the transmission gain to 64 and the decode threshold to 24.

[DTMF Control]: When [On] is selected, other radios can control this device by sending the same DTMF code as the listening/stun/kill/wake-up code set on this device

[TX Voice Refresh Time]: Changes the refresh interval for the sound pressure bar during transmission.

[Rx RSSI Refresh]: Changes the refresh interval for the signal strength display. When the signal is weak, if the refresh speed of the signal strength display is too fast, it may introduce interference noise. In such cases, you can increase the refresh time interval to avoid this issue.

[Temporary tuning]

To adjust the receiving sensitivity, enable [Temporary Receive Threshold Open], then adjust [Temporary RSSI Threshold] and [Temporary Noise Threshold]. The higher the RSSI value, the harder it is to open the reception, and vice versa. Noise behaves oppositely—higher values make it easier to open reception, and lower values make it harder to open.

To adjust the transmission power, enable [Temporary Power Open], then adjust the power tuning values for different frequency ranges. When the tuning value exceeds a certain limit (which varies for each device), continuing to adjust may only increase the current without raising the power and could potentially damage the power amplifier or other components. Therefore, it is not recommended to set the tuning value too high.

Note: Users who are not familiar with the technical specifications of the radio should avoid using the temporary debugging function, as improper use may cause component damage

CH Settings

[CTC/DCS], [RX CTC/DCS], [TX CTC/DCS]: CTC/DCS: Used to set the sub-audio type and sub-audio code for the current channel.

You can switch the sub-audio type using the * key.

[TX Freq]: When setting the repeater frequency, you can directly set the transmission frequency value in this menu, without needing to configure the [Frequency Offset] and [Frequency Offset Direction].

[DCS Encryption Type]: Select [Encryption 1/2/3] to encrypt the standard DCS, which only applies to DCS. Select [Mute Code], and the sub-audio set for the current channel will be disabled, replaced by using [Mute code] as the sub-audio for the current channel.

[Mute Code]: The non-standard digital sub-audio frequencies of other radios measured through the one-click frequency measurement function..

[Scan Add]: When [Remove] is selected, the channel will no longer be scanned when using the scanning function.

[Offset Direction] Before setting the frequency offset direction, please first set the [Frequency Offset]. When [Up Offset] is selected, the transmit frequency = receive frequency + frequency offset.
When [Down Offset] is selected, the transmit frequency = receive frequency - frequency offset..

[Offset Freq]: If you need to disable the frequency offset for the current channel, set the frequency offset to 0.

[AM/FM RX]: Used to select the receiving modulation mode of the transceiver.

Zone Settings

The device can set up to 256 zones. Enter the zone settings menu to edit different zones and select channel members by using the # key to choose or cancel channels.

FM Radio

[Call Signal Reception in Radio Mode]: When enabled, the device will listen for calls on the main channel while in radio mode.

[Channel List]: The list includes 128 preset radio channels. Select a channel and press the — key to confirm and edit the channel name or set it as the current radio channel.

Time Management

[APO]: [Enable] or [Disable] the automatic shutdown feature.

[APO Timer]: After enabling the automatic shutdown function, if no operation is performed on the device within the set time, the device will automatically enter a low-power sleep mode (not a complete shutdown, the battery will still consume power in this state.

[AWU]: Enable or Disable Auto Wake-Up Function.

[AWU Timer]: When the machine reaches the preset wake-up timer after automatically shutting down, it will end the sleep mode and automatically power on to return to normal working status..

[System Time]: Set the system time of the transceiver according to actual needs to ensure the accuracy of the displayed time.

Trouble Shooting Guide

No power on	Battery is dead or not inserted properly	Check battery charge and connection
No Transmission	PTT (Push-To-Talk) button not pressed or faulty	Ensure PTT is pressed; check for damage
Poor Audio Quality	Weak signal or interference	Move to a clear area; adjust antenna
Short Battery Life	Old battery or high power usage	Replace battery; use power-saving mode
Cannot Receive Signal	Wrong channel or squelch level set	Verify channel settings; adjust squelch
Distorted Sound	Volume too high or speaker clogged	Lower volume; clean speaker grille
Overheating	Prolonged transmission or faulty unit	Allow cooldown; check ventilation
Stuck in One Channel	Lock feature enabled	Disable channel lock function
The radio keep transmitting	VOX may be turned on or the squelch level is too sensitivity	Turn off VOX or adjust squelch level

Note: if the above solution can't fix your problems, or you may have some other inquiry, please contact our technical support by email or live chat.

Technical Specification

General

Frequency Range	Radio: FM 64-108MHz SW 2.3-30MHz MW 520-1710KHz LW 153-279KHz RX: 18-620MHz 840-1000MHz TX: 18-32MHz 136-174MHz 400-520MHz
Channel Capacity	1024 Channels +3*VFO Channels
Channel Spacing (W/N)	Analog:25kHz/12.5kHz Digital:12.5K
Voltage	7.4V DC
Working Mode	Same frequency simplex,different frequency simplex
Antenna	Removable Antenna
Frequency Stability	±2.5ppm
Working Temperature	-20℃ ~ +60℃
Dimension	149 * 64 * 37 about 307g

Receiving Part

Modulation Mode	F3E
Maximum Frequency deviation (W/N)	≤5KHz / ≤2.5KHz
Output Power(UHF/VHF)	≤10W
TX Current	≤2500mA

Transmitting Part

Sensitivity (W/N)	0.22μV/ 0.25μV 12dB SINAD
Inter modulation (W/N)	65dB/ 60dB
Audio Distortion	< 5%
Audio Output Power	≤1W (16Ω)
RX Current	≤350mA
Standby current	≤100mA

Note: The above specifications may change due to technical improvement without prior notice or liability.

SAFETY & GENERAL INFORMATION

FCC WARNING

Any changes or modifications not expressly approved by the party responsible for compliance could void the user's authority to operate the equipment.

This device complies with part 15 of the FCC Rules.

Operation is subject to the following two conditions:

- (1) This device may not cause harmful interference, and
- (2) This device must accept any interference received, including interference that may cause undesired operation.

Note: This equipment has been tested and found to comply with the limits for a Class B digital device, pursuant to part 15 of the FCC Rules. These limits are designed to provide reasonable protection against harmful interference in a residential installation. This equipment generates, uses and can radiate radio frequency energy and, if not installed and used in accordance with the instructions, may cause harmful interference to radio communications. However, there is no guarantee that interference will not occur in a particular installation. If this equipment does cause harmful interference to radio or television reception, which can be determined by turning the equipment off and on, the user is encouraged to try to correct the interference by one or more of the following measures:

Reorient or relocate the receiving antenna.

Increase the separation between the equipment and receiver.

Connect the equipment into an outlet on a circuit different from that to which the receiver is connected.

Consult the dealer or an experienced radio/TV technician for help.

Safety Information for Radios

Your wireless handheld portable transceiver contains a low power transmitter. When the talk button is pushed, it sends out radio frequency (RF) signals. The device is authorized to operate at a duty factor not to exceed 50%. In August 1996, the Federal Communications Commission (FCC) adopted RF exposure guidelines with safety levels for handheld wireless devices.

Important

FCC RF Exposure Requirements: For body-worn operation, this radio has been tested and meets the FCC RF exposure guidelines when used with accessories supplied or designated for this product. Use of other accessories may not ensure compliance with FCC RF exposure guidelines. Use only the supplied antenna. Unauthorized antennas, modifications or attachments could damage the transmitter and may violate FCC regulations.

Normal Position

Hold the transmitter approximately 25 mm from your face and speak in a normal voice, with the antenna pointed up and away.



- All articles displaying this symbol on the body, packaging or instruction manual of same, must not be thrown away into normal disposal bins but brought to specialised waste disposal centres. Here, the various materials will be divided by characteristics and recycled, thus making an important contribution to environmental protection.



Compliance with RF Exposure Standards

This two way radio uses electromagnetic energy in the radio frequency (RF) spectrum to provide communications between two or more users over a distance. It uses radio frequency (RF) energy or radio waves to send and receive calls. RF energy is one form of electromagnetic energy. Other forms include, but are not limited to, sunlight and x-rays. RF energy, however, should not be confused with these other forms of electromagnetic energy, which when used improperly, can cause biological damage. Very high levels of x-rays, for example, can damage tissues and genetic material.

Experts in science, engineering, medicine, health, and industry work with organizations to develop standards for safe exposure to RF energy. These standards provide recommended levels of RF exposure for both workers and the general public. These recommended RF exposure levels include substantial margins of protection

Local Government Regulations

When two-way radios are used as a consequence of employment, the Local Government Regulations requires users to be fully aware of and able to control their exposure to meet occupational requirements. Exposure awareness can be facilitated by the use of a product label directing users to specific user awareness information. Your Radtel two way radio has a RF Exposure Product Label. Also, your Radtel user manual, or separate safety booklet includes

information and operating instructions required to control your RF exposure and to satisfy compliance requirements

Radio License

Governments keep the radios in classification, most of the classified walkie-talkie need to get local government License, and operation is allowed. The detailed classification and the use of your two radios, please contact the local government radio management departments.



The CE marking means: Hereby, Xiamen Radtel Electronics Co.,Ltd declares that the radio equipment type is in compliance with the RED Directive 2014/53/EU and the ROHS Directive 2011/65/EU and the WEEE Directive 2012/19/EU. The full text of the EU declaration of conformity is available in this manual or at the following internet address: www.radtel.com



WARNING

- Only use this equipment for the end that this has been manufactured. The manufacturer and the salesperson won't accept any responsibility and the guarantee will invalidity in the event of inadequate use of the transceiver.
- This equipment doesn't have components that the user can repair. Always consult to the Authorized Technical Service for any repair.

- It should not put into operation the equipment neither to turn off it installing and removing the battery pack. Always use the ON/OFF control.
- Install the battery pack and the accessories (optionals) correctly, according to the indications given in this instruction manual.
- Never transmit with the transceiver if the antenna is damaged.
- Don't transmit with the transceiver for extended period of time.
- Don't touch the antenna with the hand or with any part of the body when the equipment is transmitting.
- In the event malfunction of the transceiver or of their battery charger (scent to burnt, smoke, etc.), turn off it immediately or disconnect the battery charger of the AC wall outlet and consult to the Technical Service.
- Don't introduce any object for the holes of the speaker or for the transceiver connectors. • If it uses an external headset (optional), reduce to the possible the maximum volume level; avoid levels of very high audio.
- Don't expose the equipment or the battery charger direct to the water, direct to the sunlight for an extended period of time, not place near a heat source (radiators, etc.) to blows, to the powder excess or dirt, to the fire, to explosive or another type of dangerous conditions. Don't stored the transceiver inside a vehicle that is parked in the sunlight.
- Avoid the humidity condensation. The air humidity is deposited in the transceiver when place of a cold atmosphere to other warm, making that the equipment doesn't work correctly. If condensation takes place in the equipment, clean a dry cloth and wait to that dries off to

- light it. • Don't place anything on the transceiver that can spill out on the same one.
- If the transceiver caused interferences in the video recorder, DVD, radio and television receiver, or to any other electronic equipments, take it away from the apparatus in question.
- Don't use this transceiver in the vicinity of other electronic equipments, especially next to medical equipments. It can cause interferences in other equipments.
- Turn off and do not use the equipment in areas where their use is restricted or prohibited (e.g. coal gas , areas with explosion atmosphere, areas where it can interference the operation of other equipments, on board airships, airports, etc.).
- Don't operate this transceiver while it is driving a vehicle, use hands free systems ("VOX" function) and respect the traffic police indications.
- To clean the equipment and/or the battery charger being OFF and with an antistatic cloth (preferably) or a humid (not wet) cloth.
- Don't pulverize directly with any liquid or product on the transceiver, battery pack or battery charger and never use for their cleaning polish home products, detergents, alcohol or solvent.
- Don't use for the cleaning a dry cloth, it could cause static sock.
- The use of not compatible accessories with the transceiver they could limit the operation of the transceiver, and even to damages invalidating the guarantee.
- Explosion risk if it replaces the battery pack for an incompatible one.