

The RF Line NPN Silicon RF Power Transistor

Designed primarily for applications as a high-power linear amplifier from 2.0 to 30 MHz.

- Specified 28 Volt, 30 MHz Characteristics —
Output Power = 150 W (PEP)
Minimum Gain = 10 dB
Efficiency = 40%
- Intermodulation Distortion @ 150 W (PEP) —
IMD = -30 dB (Min)
- 100% Tested for Load Mismatch at all Phase Angles with 30:1 VSWR

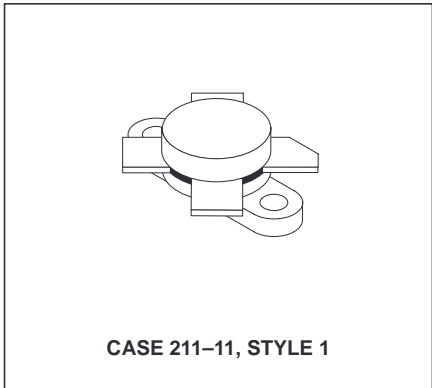
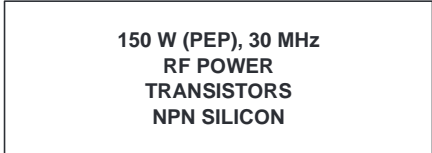

MAXIMUM RATINGS

Rating	Symbol	Value	Unit
Collector-Emitter Voltage	V_{CEO}	40	Vdc
Collector-Base Voltage	V_{CBO}	85	Vdc
Emitter-Base Voltage	V_{EBO}	3.0	Vdc
Collector Current — Continuous	I_C	20	Adc
Withstanding Current — 10 s	—	30	Adc
Total Device Dissipation @ $T_C = 25^\circ\text{C}$ Derate above 25°C	P_D	290 1.66	Watts W/ $^\circ\text{C}$
Storage Temperature Range	T_{stg}	-65 to +150	$^\circ\text{C}$

THERMAL CHARACTERISTICS

Characteristic	Symbol	Max	Unit
Thermal Resistance, Junction to Case	$R_{\theta JC}$	0.6	$^\circ\text{C}/\text{W}$

ELECTRICAL CHARACTERISTICS ($T_C = 25^\circ\text{C}$ unless otherwise noted.)

Characteristic	Symbol	Min	Typ	Max	Unit
----------------	--------	-----	-----	-----	------

OFF CHARACTERISTICS

Collector-Emitter Breakdown Voltage ($I_C = 200 \text{ mAdc}$, $I_B = 0$)	$V_{(BR)CEO}$	35	—	—	Vdc
Collector-Emitter Breakdown Voltage ($I_C = 100 \text{ mAdc}$, $V_{BE} = 0$)	$V_{(BR)CES}$	85	—	—	Vdc
Collector-Base Breakdown Voltage ($I_C = 100 \text{ mAdc}$, $I_E = 0$)	$V_{(BR)CBO}$	85	—	—	Vdc
Emitter-Base Breakdown Voltage ($I_E = 10 \text{ mAdc}$, $I_C = 0$)	$V_{(BR)EBO}$	3.0	—	—	Vdc
Collector Cutoff Current ($V_{CE} = 28 \text{ Vdc}$, $V_{BE} = 0$, $T_C = 25^\circ\text{C}$)	I_{CES}	—	—	20	mAdc

(continued)

ELECTRICAL CHARACTERISTICS — continued ($T_C = 25^\circ\text{C}$ unless otherwise noted.)

Characteristic	Symbol	Min	Typ	Max	Unit
ON CHARACTERISTICS					
DC Current Gain ($I_C = 5.0 \text{ Adc}$, $V_{CE} = 5.0 \text{ Vdc}$)	h_{FE}	15	30	120	—

DYNAMIC CHARACTERISTICS

Output Capacitance ($V_{CB} = 28 \text{ Vdc}$, $I_E = 0$, $f = 1.0 \text{ MHz}$)	C_{ob}	—	420	—	pF
---	----------	---	-----	---	----

FUNCTIONAL TESTS

Common-Emitter Amplifier Power Gain ($V_{CC} = 28 \text{ Vdc}$, $P_{out} = 150 \text{ W (PEP)}$, $I_{C(max)} = 6.7 \text{ Adc}$, $I_{CQ} = 150 \text{ mAdc}$, $f = 30, 30.001 \text{ MHz}$)	G_{PE}	10	13	—	dB
Collector Efficiency ($V_{CC} = 28 \text{ Vdc}$, $P_{out} = 150 \text{ W (PEP)}$, $I_{C(max)} = 6.7 \text{ Adc}$, $I_{CQ} = 150 \text{ mAdc}$, $f = 30, 30.001 \text{ MHz}$)	η	—	45	—	%
Intermodulation Distortion (1) ($V_{CE} = 28 \text{ Vdc}$, $P_{out} = 150 \text{ W (PEP)}$, $I_C = 6.7 \text{ Adc}$, $I_{CQ} = 150 \text{ mAdc}$, $f = 30, 30.001 \text{ MHz}$)	IMD	—	-33	-30	dB
Output Power ($V_{CE} = 28 \text{ Vdc}$, $f = 30 \text{ MHz}$)	P_{out}	150	—	—	Watts (PEP)

NOTE:

- To Mil-Std-1311 Version A, Test Method 2204, Two Tone, Reference each Tone.

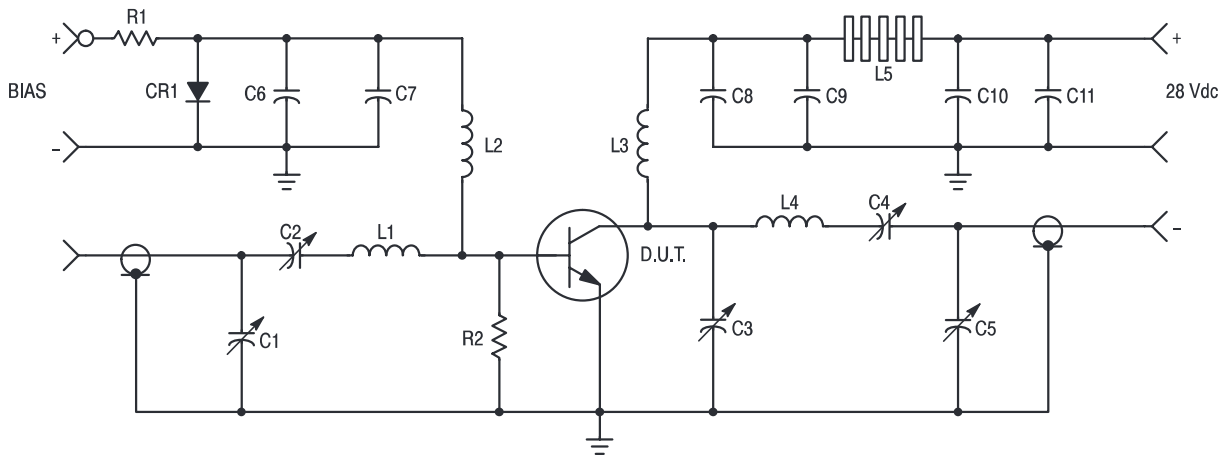

C1, C2, C3, C5 — 170–680 pF, ARCO 469
 C4 — 80–480 pF, ARCO 466
 C6, C8, C11 — ERIE 0.1 μF , 100 V
 C7 — MALLORY 500 μF , 15 V Electrolytic
 C9 — UNDERWOOD 1000 pF, 350 V
 C10 — 10 μF , 50 V Electrolytic
 R1 — 10 Ω , 25 Watt Wire Wound
 R2 — 10 Ω , 1.0 Watt Carbon
 CR1 — 1N4997

L1 — 3 Turns, #16 Wire, 5/16" I.D., 5/16" Long
 L2 — 10 μH Molded Choke
 L3 — 12 Turns, #16 Enameled Wire, Close Wound, 1/4" Dia.
 L4 — 5 Turns, 1/8" Copper Tubing
 L5 — 10 Ferrite Beads — FERROXCUBE #56–590–65/3B

Figure 1. 30 MHz Test Circuit Schematic

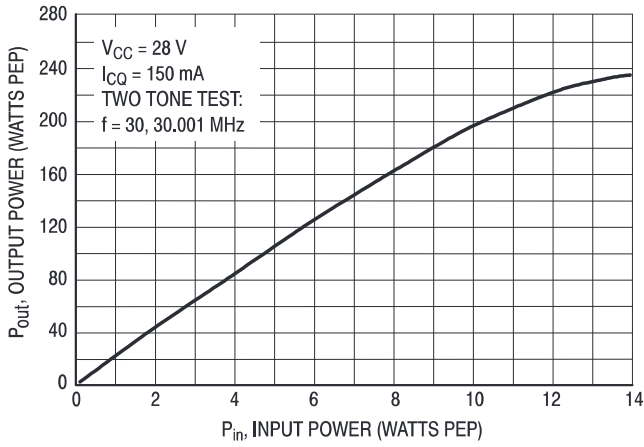

Figure 2. Output Power versus Input Power

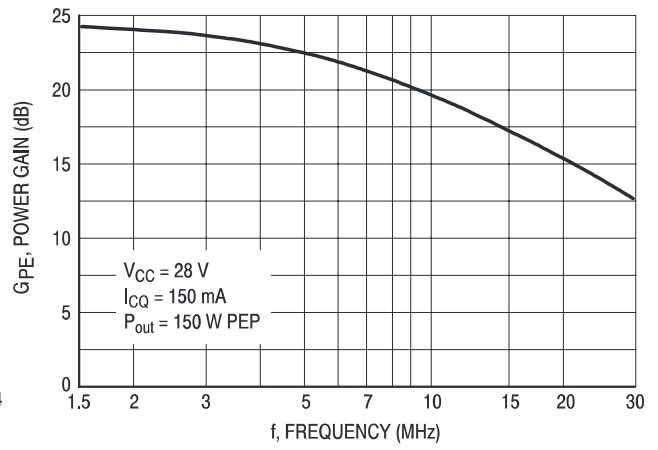

Figure 3. Power Gain versus Frequency

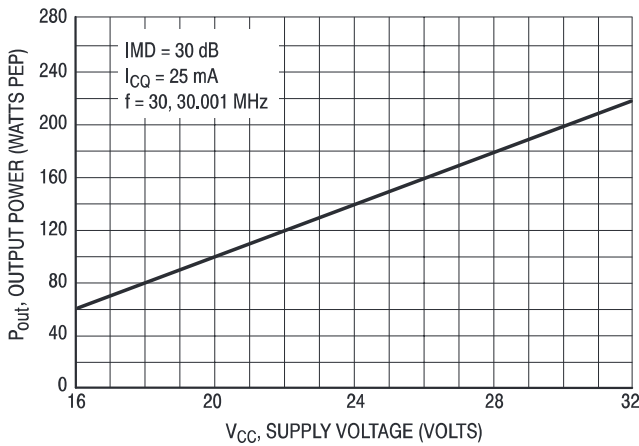

Figure 4. Linear Output Power versus Supply Voltage

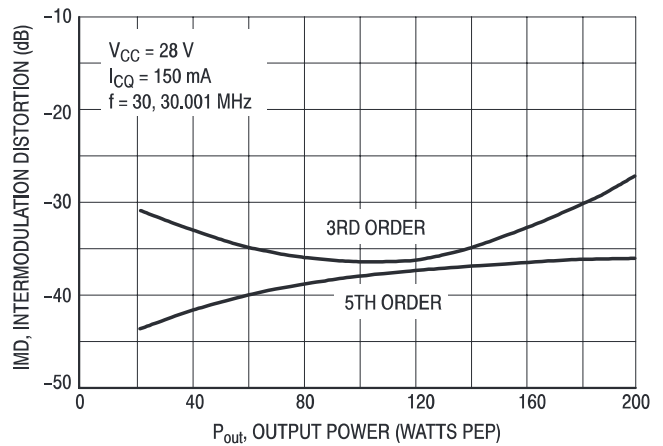

Figure 5. Intermodulation Distortion versus Output Power

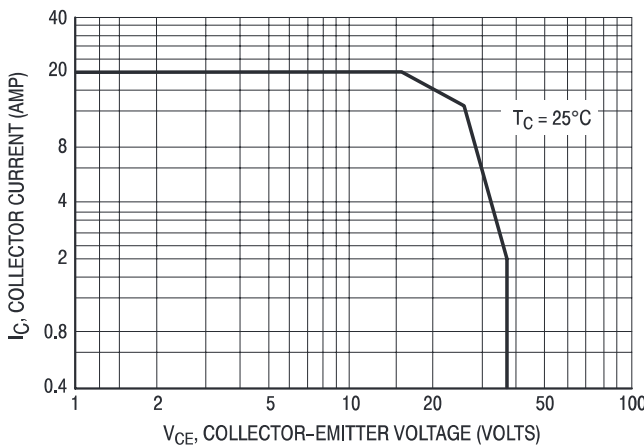

Figure 6. DC Safe Operating Area

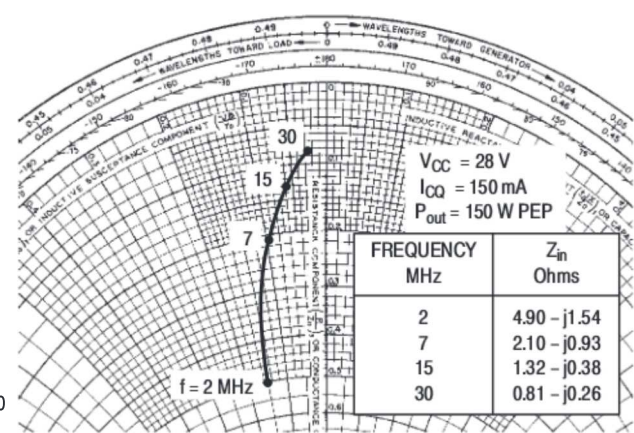

Figure 7. Series Input Impedance

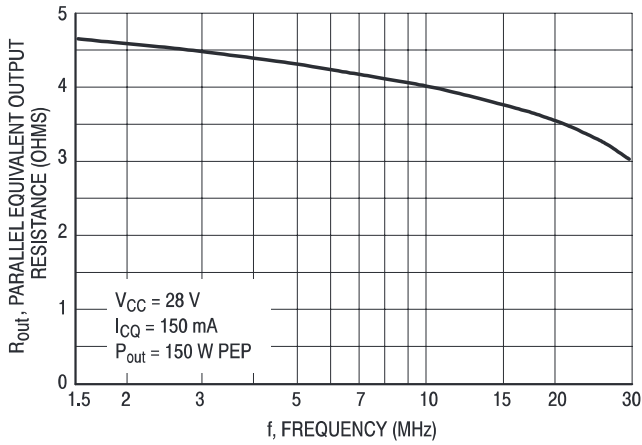

Figure 8. Output Resistance versus Frequency

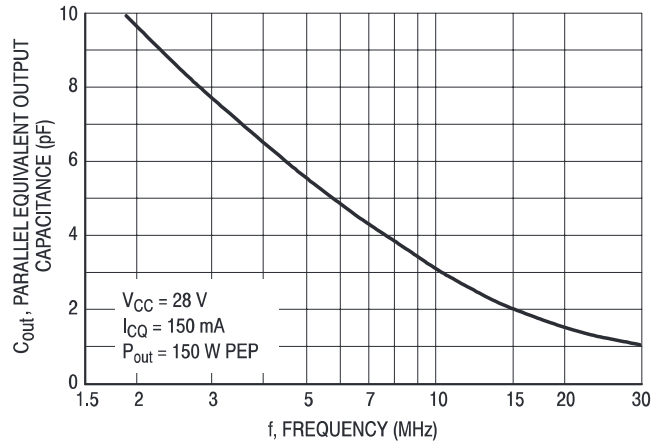
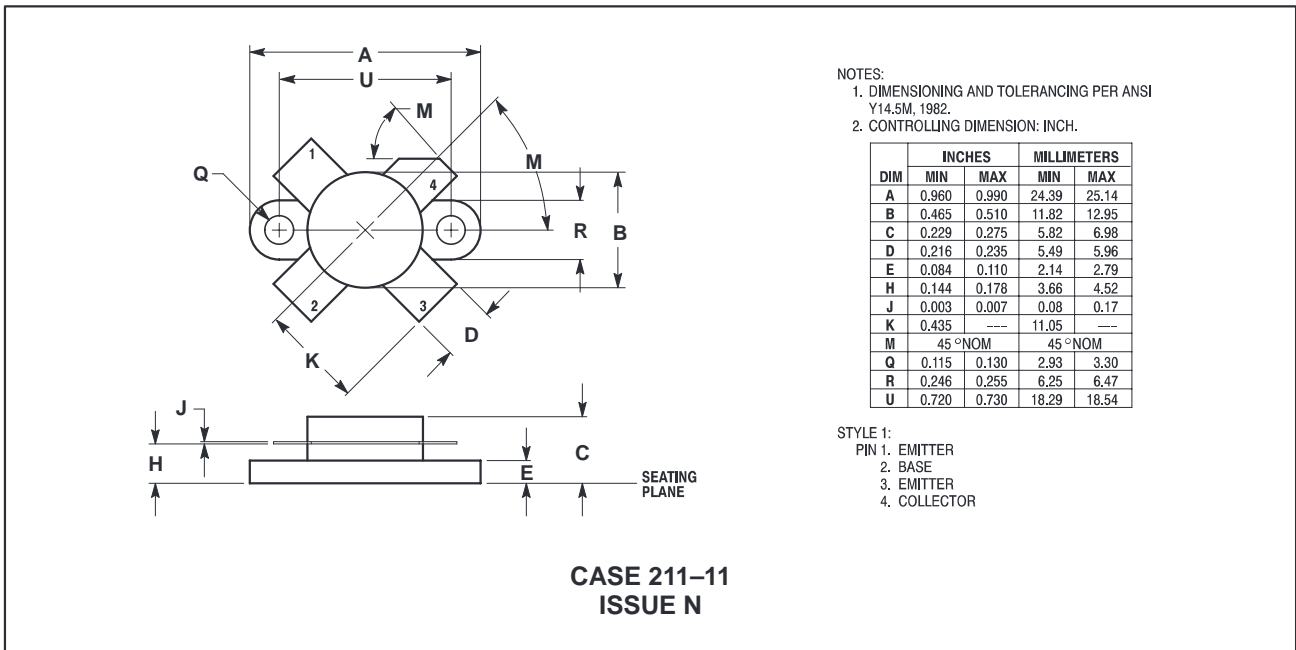

Figure 9. Output Capacitance versus Frequency

PACKAGE DIMENSIONS



Specifications subject to change without notice.

- North America: Tel. (800) 366-2266, Fax (800) 618-8883
- Asia/Pacific: Tel.+81-44-844-8296, Fax +81-44-844-8298
- Europe: Tel. +44 (1344) 869 595, Fax+44 (1344) 300 020

Visit www.macom.com for additional data sheets and product information.

REV 6